

ARMY PUBLIC SCHOOL KALUCHAK
HOLIDAYS HOME WORK-XII

SUBJECT- PHYSICS

1. The plot of the variation of potential difference A across a combination of three identical cells in series, versus current is shown along the question. What is the emf and internal resistance of each cell?

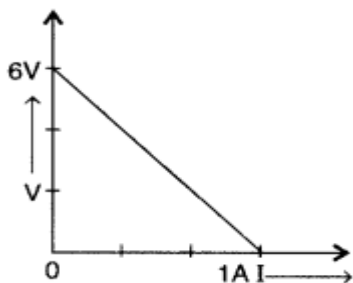

2. Nichrome and copper wires of same length and same radius are connected in series. Current I is passed through them. Which wire gets heated up more? Justify your answer.

3. Two metallic wires of the same material have the same length but cross-sectional area is in the ratio $1 : 2$. They are connected

(i) in series and

(ii) in parallel. Compare the drift velocities of electrons in the two wires in both the cases (i) and (ii).

4. Explain the term 'drift velocity' of electrons in a conductor. Hence obtain the expression for the current through a conductor in terms of 'drift velocity'. Derive an expression for the resistivity of a good conductor, in terms of the relaxation time of electrons.

5. Calculate the current drawn from the battery in the given network.

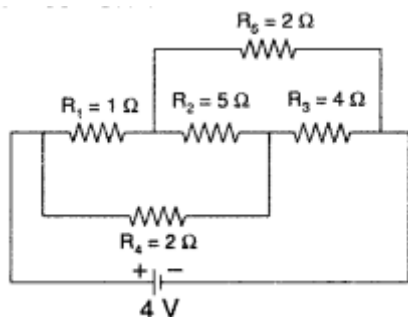

6. In the given circuit, assuming point A to be at zero potential, use Kirchhoff's rules to determine the potential A at point B.

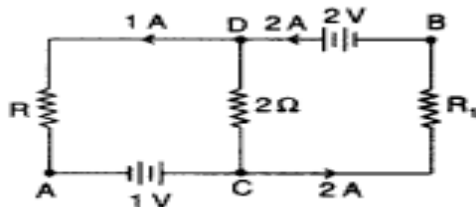

7. A battery of emf 10 V and internal resistance 3Ω is connected to a resistor. If the current in the circuit is 0.5 A , find

- (i) the resistance of the resistor;
- (ii) the terminal voltage of the battery.

8. A battery of emf 6 V and internal resistance 2Ω is connected to a resistor. If the current in the circuit is 0.25 A , find

- (i) the resistance of the resistors;
- (ii) the terminal voltage of the battery.

9. The network PQRS, shown in the circuit diagram, has the batteries of 4 V and 5 V and negligible internal resistance. A milliammeter of 20Ω resistance is connected between P and R. Calculate the reading in the milliammeter.

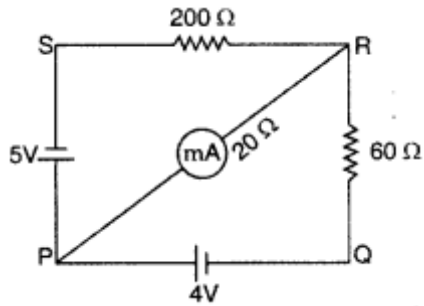

10. The network PQRS, shown in the circuit diagram, has the batteries of 5V and 10V and negligible internal resistance. A milliammeter of 50Ω resistance is connected between P and R. Calculate the reading in the milliammeter.

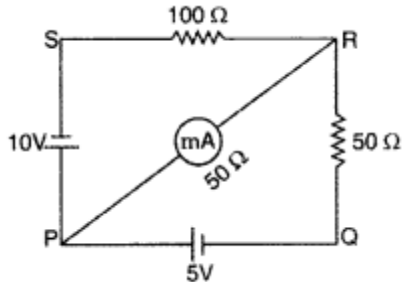

11. Use Kirchhoff's rules to determine the value of the current I_1 flowing in the circuit shown in the figure.

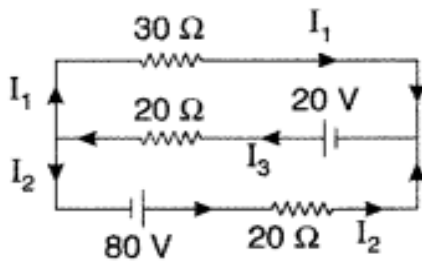

12. Draw a graph showing variation of resistivity with temperature for nichrome. Which property of nichrome is used to make standard resistance coils?
13. A battery of emf E and internal resistance r when connected across an external resistance of 12 Ω, produces a current of 0.5 A. When connected across a resistance of 25 Ω, it produces a current of 0.25 A. Determine
- the emf and
 - the internal resistance of the cell.
14. A uniform wire of resistance 12 Ω is cut into three pieces so that the ratio of the resistances $R_1 : R_2 : R_3 = 1 : 2 : 3$ and the three pieces are connected to form a triangle across which a cell of emf 8V and internal resistance 1 Ω is connected as shown. Calculate the current through each part of the circuit.

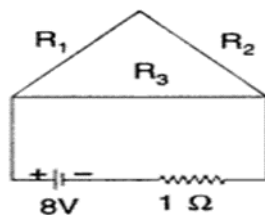

15. Estimate the average drift speed of conduction electrons in a copper wire of cross-sectional area $1.0 \times 10^{-7} \text{ m}^2$ carrying a current of 1.5 A. Assume the density of conduction electrons to be $9 \times 10^{28} \text{ m}^{-3}$.

- 16.(i) Use Kirchhoff's rules to obtain conditions for the balance condition in a Wheatstone bridge.

- (ii) Calculate the value of the resistance R in the circuit shown in the figure so that the current is 0.2 A. What would be the potential difference between points A and B?

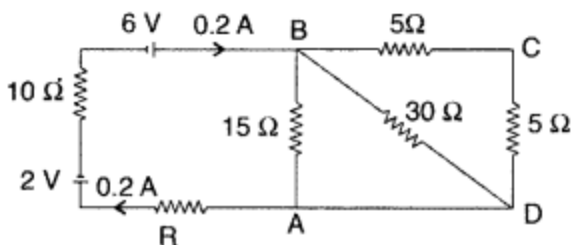

17. Use Kirchhoff's rules to determine the potential difference between the points A and D when no current flows in the arm BE of the electric network shown in the figure.

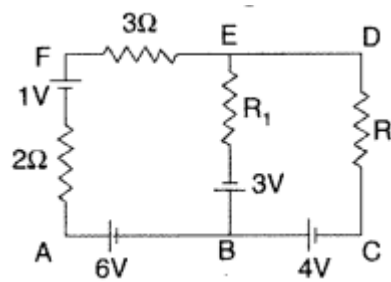

18. Two cells of emfs 1.5 V and 2.0 V having internal resistance 0.2 Ω and 0.3 Ω respectively are connected in parallel. Calculate the emf and internal resistance of the equivalent cell.

(ii) Using Kirchhoff's rules determine the value of unknown resistance R into circuit so that no current flows through 4ohm resistance. Also find the potential difference between A and D. (Delhi 2012)

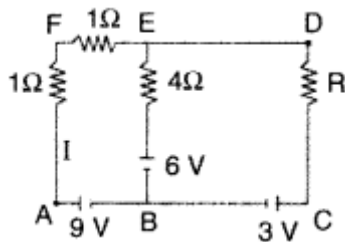

19. (i) State Kirchhoff's rules. Use these rules to write the expressions for the current I_1 , I_2 and I_3 in the circuit diagram shown.

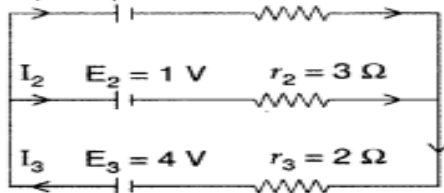

(ii) In the circuit shown, $R_1 = 4\Omega$, $R_2 = R_3 = 15\Omega$, $R_4 = 30\Omega$ and $E = 10V$. Calculate the equivalent resistance of the circuit and the current in each resistor. (Delhi 2010)

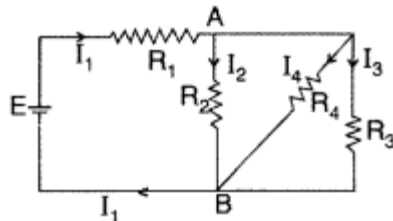

20. State Kirchhoff's rules. Apply Kirchhoff's rules to the loops ACBPA and ACBQA to write the expressions for the currents I_1 , I_2 and I_3 in the network.

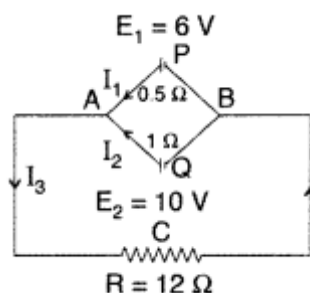

(ii) Calculate the value of the resistance R in the circuit shown in the figure so that the current in the circuit is 0.2 A. What would be the potential difference between points B and E?

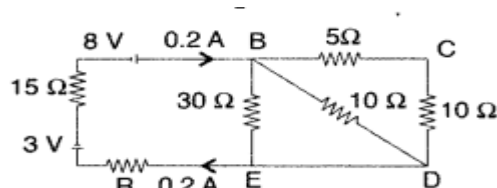

SUBJECT- CHEMISTRY

1. Explain why aquatic species are more comfortable in cold water rather than in warm water.
2. State Henry's law and mention two of its important applications.
3. Why do gases nearly always tend to be less soluble in liquids as the temperature is raised?
4. 18 g of glucose, $C_6H_{12}O_6$ (Molar mass – 180 g mol⁻¹) is dissolved in 1 kg of water in a sauce pan. At what temperature will this solution boil? (K_b for water = 0.52 K kg mol⁻¹, boiling point of pure water = 373.15 K)
5. Calculate the mass of compound (molar mass = 256 g mol⁻¹) to be dissolved in 75 g of benzene to lower its freezing point by 0.48 K (K_f = 5.12 K kg mol⁻¹).
6. Define azeotropes. What type of azeotrope is formed by positive deviation from Raoult's law? Given an example.
7. (i) On mixing liquid X and liquid Y, volume of the resulting solution decreases. What type of deviation from Raoult's law is shown by the resulting solution? What change in temperature would you observe after mixing liquids X and Y?

(ii) What happens when we place the blood cell in water (hypotonic solution)? Give reason.
8. Define osmotic pressure of a solution. How is the osmotic pressure related to the concentration of a solute in a solution?
9. 100 mg of a protein is dissolved in just enough water to make 10.0 mL of solution. If this solution has an osmotic pressure of 13.3 mm Hg at 25°C, what is the molar mass of the protein?

($R = 0.0821 \text{ L atm mol}^{-1} \text{ K}^{-1}$ and $760 \text{ mm Hg} = 1 \text{ atm}$.)

10. (a) For a reaction $A + B \rightarrow P$, the rate law is given by, $r = k[A]^{1/2} [B]^2$.

What is the order of this reaction?

- (b) A first order reaction is found to have a rate constant $k = 5.5 \times 10^{-14} \text{ s}^{-1}$. Find the half life of the reaction.

11. Rate constant k for a first order reaction has been found to be $2.54 \times 10^{-3} \text{ sec}^{-1}$. Calculate its 3/4th life, ($\log 4 = 0.6020$).

12. For a decomposition reaction the values of rate constant k at two different temperatures are given below :

$$k_1 = 2.15 \times 10^{-8} \text{ L mol}^{-1} \text{ s}^{-1} \text{ at } 650 \text{ K} \text{ and } k_2 = 2.39 \times 10^{-7} \text{ L mol}^{-1} \text{ s}^{-1} \text{ at } 700 \text{ K}$$

Calculate the value of activation energy for this reaction.

$$(R = 8.314 \text{ J K}^{-1} \text{ mol}^{-1})$$

13. (a) A reaction is first order in A and second order in B.
 - (i) Write differential rate equation.
 - (ii) How is rate affected when concentration of B is tripled?
 - (iii) How is rate affected when concentration of both A and B is doubled?(b) What is molecularity of a reaction?

14. The rate of a reaction becomes four times when the temperature changes from 293 K to 313 K. Calculate the energy of activation (E_a) of the reaction assuming that it does not change with temperature. [$R = 8.314 \text{ JK}^{-1} \text{ mol}^{-1}$, $\log 4 = 0.6021$]

15. Calculate emf of the following cell at 25°C :

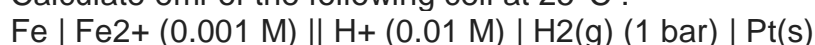

$$E_0(\text{Fe}^{2+} \mid \text{Fe}) = -0.44 \text{ V} \quad E_0(\text{H}^+ \mid \text{H}_2) = 0.00 \text{ V}$$

16. Calculate e.m.f. of the following cell at 298 K:

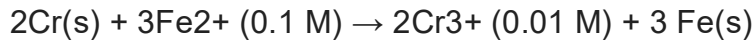

Given: $E^0(\text{Cr}^{3+} | \text{Cr}) = -0.74 \text{ V}$ $E^0(\text{Fe}^{2+} | \text{Fe}) = -0.44 \text{ V}$

17. Accounts for the following

- (i) Rusting of iron is quicker in saline water than in ordinary water.
- (ii) Blocks of magnesium are strapped to the steel hubs of ocean going ships.

18. Calculate the time to deposit 1.27 g of copper at cathode when a current of 2 A was passed through the solution of CuSO_4 .

(Molar mass of Cu = 63.5 g mol⁻¹, 1 F = 96500 C mol⁻¹)

19. Conductivity of $2.5 \times 10^{-4} \text{ M}$ methanoic acid is $5.25 \times 10^{-5} \text{ S cm}^{-1}$ Calculate its molar conductivity and degree of dissociation.

Given: $\lambda^\circ(\text{H}^+) = 349.5 \text{ S cm}^2 \text{ mol}^{-1}$ and $\lambda^\circ(\text{HCOO}^-) = 50.5 \text{ S cm}^2$

20. What type of a battery is lead storage battery? Write the anode and cathode reactions and the overall cell reaction occurring in the operation of a lead storage battery.

SUBJECT- BIOLOGY

PROJECT: To prepare an investigatory project from any one topic given in the curriculum.

ANSWER THE FOLLOWING QUESTIONS:

Q1. A true breeding pea plant, homozygous dominant for inflated green pods is crossed with another pea plant with constricted yellow pods (ffgg). With the help of punnett square show the above cross and mention the results obtained phenotypically and genotypically in F1 generation?

Q2. Study the Pedigree chart given below and answer the questions that follow:

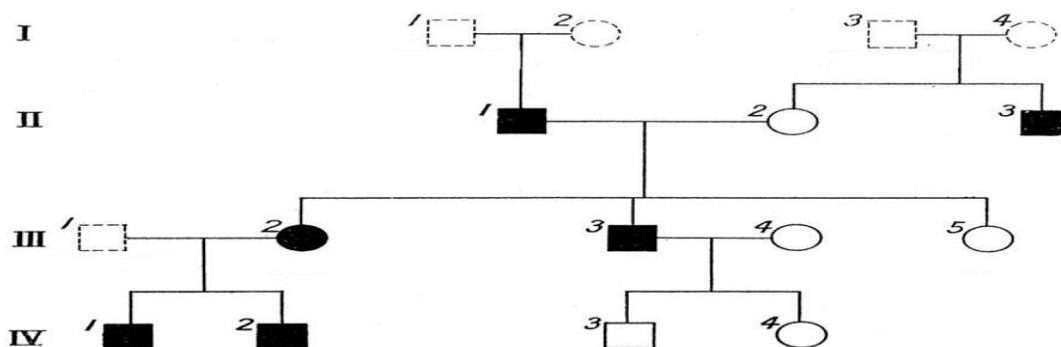

(a) On the basis of the inheritance pattern exhibited in this pedigree chart, what conclusion can you draw about the pattern of inheritance?

(b) If the female is homozygous for the affected trait in this pedigree chart, then what percentage of her sons will be affected.

(c) Give the genotype of offsprings 1,2,3 and 4 in III generation

Q3. (a) (i) Expand the abbreviations given below, used for different modes of assisted reproductive technologies : 2

(1) ZIFT (2) ICSI (3) IUT (4) GIFT

(ii) Which one of them cannot be considered as a procedure of IVF ? Give reasons in support of your answer.

Q4. (b) Observe the diagram given below showing thmenstrual cycle of a normal human female and answer the questions that follow :

(i) What are the suitable technical terms used for the following ?

(1) Days 1 7 (2) Days 8 12 (3) Days 16 28 (4) Days 13 15

(ii) Explain the role of ovarian and pituitary hormones during the following time periods :

(1) Days 8 12 (2) Days 13 15 (3) Days 16 28

Q5. (b) Differentiate between the following :

- (i) Perisperm and Pericarp
- (ii) Syncarpous pistil and Apocarpous pistil
- (iii) Plumule and Radicle

Q6. The graph given below shows the number of primordial follicles per ovary in women at different ages. Study the graph and answer the questions that follow.

(a) What is the average age of women at the onset of menopause ?

(b) At what age are maximum primordial follicles present in the ovary, according to the giving graph?

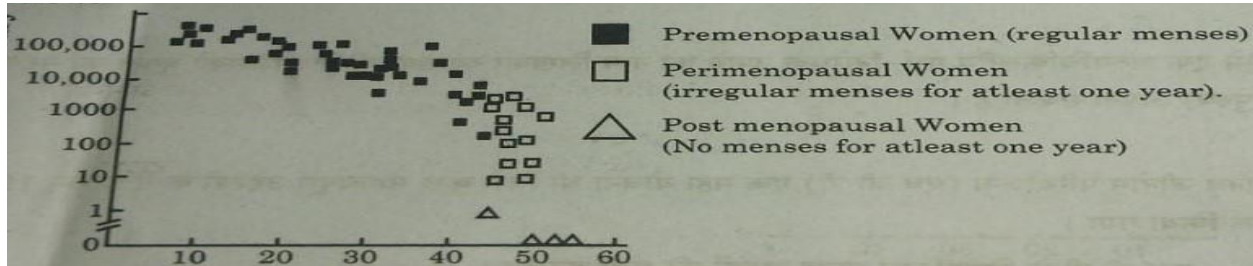

Q7. What are point mutations? How is aneuploidy main cause of genetic disorders. Draw and explain.

Q8. Sometimes an error may occur during meiosis of cell cycle, where the sister chromatids fail to segregate called nondisjunction, leading to the production of abnormal gametes with altered chromosome number. On fertilisation such gametes develop into abnormal individuals.

a. State what is aneuploidy.

b. If during spermatogenesis, the chromatids of sex chromosomes fail to segregate during meiosis, write only the different types of gametes with altered chromosome number that could possibly be produced. [1] c. A normal human sperm (22+Y) fertilises an ovum (22+XX). Name the disorder.

Q9. (a) (i) Explain the monosporic development of embryo sac in the ovule of an angiosperm. [

(ii) Draw a diagram of the mature embryo sac of an angiospermic ovule and label any four parts in it.

Q10. (i) Explain the formation of placenta after the implantation in a human female.

(ii) Draw a diagram showing human foetus within the uterus and label any four parts in it.

Q11. The diagram below shows the sequence of amino acids in part of haemoglobin molecule.

Val	His	Leu	Thr	Pro	Glu	Glu	haemoglobin chain
							mRNA
CAT	GTA	AAT	TGA	GGA	*CTT	CTC	DNA

Key:

Val = valine
His = histidine
Leu = leucine

Thr = threonine
Pro = proline
Glu = glutamic acid

Q12. Griffith performed an experiment on Streptococcus pneumonia. What conclusions were drawn? Illustrate with experiment.

Q13. How was biochemical nature of genetic material determined? Explain.

Q14. Mention the causative organism and symptoms of any two fatal STDs.

Q15. A pregnant human female was advised to undergo MTP. It was diagnosed that the fetus she was carrying had developed from a zygote having 45 chromosomes with only one X chromosome. a) What is this condition called and how does it arise? b) Why was she advised to undergo MTP?

Q16. In shorthorn cattle, the coat colours red or white are controlled by a single pair of alleles. A calf which receives the allele for red coat from its mother and the allele for white coat from its father is called a 'roan'. It has an equal number of red and white hairs in its coat.

a) Is this an example of codominance or of incomplete dominance?

b) Give a reason for your answer.

c) With the help of genetic cross explain what will be the consequent phenotype of the calf when

- i. red is dominant over white ii. red is incompletely dominant

Q17. Draw schematic diagrams to show development of pollen grain from a microspore.

Q18. Mention the role of following in a microsporangium/male gametophyte

- a). Tapetum b) Sporogenous tissue c) sporopollinin

Q19. a). What are Sex linked diseases?

- b). Show the fate of progeny when a haemophilic male marries a carrier female.
c). Why are Haemophilic females rare to find in nature?

Q20. a). Explain sex determination in Honey Bees and Grasshoppers.

- b). What is a Barr body?

SUBJECT: ENGLISH

1. "Will they make them sing in German, even the pigeons?" A language loses its significance when it becomes the victim of colonial expansion. Justify with reference to the story.

2. "I was amazed to see how well I understood it." Why do you think Franz found the grammar lesson so easy to understand?

3. Little Franz is the narrator of the story. The name 'Franz' means 'from France'. In what way does the story being told as a first-person narrative of Franz impact your reading and understanding of the story? Provide at least one evidence from the text to support your opinion.

4. War and conflict displace people from their homes/ nations. How is this relevant for Saheb & his family?

5. Mukesh insists on being his own master. "I will be a motor mechanic", he announces. Why do you think the author does not agree with Mukesh in this context? Do you think Mukesh can realize his dream one day

6. God-given lineage condemns thousands of children to a life of abject poverty and interferes in realizing their dreams. How has this issue been portrayed in the story? Do you think Mukesh can be an exception in this regard? Justify your answer with reference to your reading of Mukesh's character traits.

7. Franklin D. Roosevelt once said, "The only thing we have to fear is fear itself." Analyze how the swimming instructor and the narrator's subsequent efforts contributed to overcoming the narrator's fear of water.

8. "Returning to the Y.M.C.A. swimming pool brought back distressing memories and rekindled childhood fears." Explore the importance of natural world references in the chapter "Deep Water."

9. Bullying by older children towards younger ones is a common issue, especially in schools. How does this phenomenon relate to William Douglas' experience at the Y.M.C.A. swimming pool? What does such behavior reveal about the attitudes of modern youth? Explain.

10. How did the concept of 'bait' illustrated through the character peddler in the story? Explain with the help of instances given in the story.

11. Both the crofter & Edla Wilmanson were kind towards the peddler. But the peddler's attitude towards the both was a mismatch. Why do you think Edla was more persuasive than the crofter in the transformation of the peddler? Make a comparative answer with instances from the text.

12. Trust is a difficult choice, which may or may not be rewarded. Examine this statement in the light of peddler's action with respect to the crofter & the ironmaster.

13. The peddler's instance calls for a need to integrate people from the marginalized sections into the mainstream society. Justify the statement with respect to Edla's demonstration of love, compassion and charity.

14. How does Pablo Neruda use the theme of silence to convey a message of introspection and unity in the poem "Keeping Quiet"? Discuss with reference to specific lines and imagery used in the poem.

15. Analyze how Pablo Neruda's "Keeping Quiet" reflects the poet's views on peace and environmental conservation. How does the poem suggest a connection between inner tranquility and the well-being of the Earth?

16. How does Kamala Das use imagery and symbolism to convey the emotional landscape of the poem "My Mother at Sixty-Six"?
17. Discuss the theme of aging and the fear of loss as presented in "My Mother at Sixty-Six."
18. Evaluate the use of ambiguity in "The Third Level" and its impact on the story's interpretation.
19. Examine the psychological dimensions of Charley's journey in "The Third Level" and discuss how the story reflects the interplay between reality and fantasy.
20. NOTICE WRITING
- a. As the Principal of Sardar Patel Vidyalaya, Lucknow, you need to draft a notice informing students of the change in school timings with effect from the 1st of October. State valid reasons for the change.
- b. As the Secretary of the History Club at Pearl Harbor Society, draft a notice informing residents of a proposed visit to important historical sites in your city.
- c. You are the Secretary of the English Literary Association of Tagore Memorial School, Patna. Write out a notice for notice-board, inviting names of those who would like to participate in the proposed inter-house debate, oratorio! And elocution contest.

SUBJECT: MATHEMATICS

- Q1. If R_1 and R_2 are equivalence relations in a set A , show that $R_1 \cap R_2$ is also an equivalence relation.
- Q2. Let $A = \mathbb{R} - \{3\}$ and $B = \mathbb{R} - \{1\}$. Let $f: A \rightarrow B$ be defined by $f(x) = \left(\frac{x-2}{x-3}\right)$, for all $x \in A$. Then show that f is bijective. Hence, find $f^{-1}(x)$.
- Q3. Show that the function $f: \mathbb{R} \rightarrow \mathbb{R}$ defined $f(x) = f(x) = \frac{x}{x+1} \forall x \in \mathbb{R}$ is neither one – one nor on to.
- Q4. Let $A = [-1, 1]$. Then discuss whether the following functions defined on A are one-one-onto or bijective: (i) $f(x) = x/2$ (ii) $g(x) = |x|$ (iii) $h(x) = x|x|$ (iv) $k(x) = x^2$
- Q5. Show that the function.
 $f: \mathbb{R} \rightarrow \{x \in \mathbb{R} : -1 < x < 1\}$ defined by $f(x) = \frac{x}{1+|x|}$, $x \in \mathbb{R}$ is one-one and onto function.
- Q6. Evaluate: $\tan \{2 \tan^{-1} (1/5)\}$
- Q7. Solve: $\cos (\tan^{-1} x) = \sin (\cot^{-1} 3/4)$
- Q8. Evaluate: $\sin [\cot^{-1} (\cos (\tan^{-1}))]$
- Q9. Evaluate: $\sin^{-1} (\cos (43\pi/5))$
- Q10. For any square matrix 'A' with real number entries, $A + A^T$ is a symmetric matrix and $A - A^T$ is a skew-symmetric matrix.
- Q11. Evaluate $\cos(\tan^{-1} \frac{3}{4})$
 Evaluate $\sin^{-1} \left(\sin \left(-\frac{17\pi}{8} \right) \right)$
- Q12. Find $\frac{dy}{dx}$ if $xy = e^{(x-y)}$.
- Q13. Sahaj wants to prepare a handmade gift for his father's birthday at Home. For making lower part of box, he takes a square piece of Cardboard of side 20cm. If x cm be the length of each side of the square cardboard which is to be cut from corners from square piece of side 20 cm, then.
- What is the volume function of open box formed by folding up the cutting corners?
 - At what rate the volume of box is changing?
 - Sahaj is interested in maximising the volume of the box. So, what should be the value of x to be cut off so that volume of box is maximum?

What are the dimensions of the open box with maximum volume?

- Q14. A particle is moving along the curve represented by the polynomial $f(x) = (x - 2)^2(x - 1)$.
 Based on above information answer the following questions:
- Find the rate at which the particle is moving.
 - What are the critical points of polynomial $f(x)$?
 - Find the interval where $f(x)$ is strictly increasing.

OR

Find the interval where $f(x)$ is strictly decreasing.

- Q15. If $x \sin(a + y) + \sin a \cos(a + y) = 0$, then prove that $\frac{dy}{dx} = \frac{\sin^2(a+y)}{\sin a}$

Q16. Let $A = \{1,2,3, \dots, 9\}$ and R be the relation in $A \times A$ defined by $(a, b) R (c, d)$ if $a + d = b + c$, for $(a, b), (c, d)$ in $A \times A$. Prove that R is an equivalence relation and also obtain the equivalence class $[(2,5)]$.

Q17. Consider $f: \mathbb{R}_+ \rightarrow [-9, \infty)$ given by $f(x) = 5x^2 + 6x - 9$. Prove that f is bijective.

Q18. Given two matrices $A = \begin{bmatrix} 1 & -1 & 0 \\ 2 & 3 & 4 \\ 0 & 1 & 2 \end{bmatrix}$ and $B = \begin{bmatrix} 2 & 2 & -4 \\ -4 & 2 & -4 \\ 2 & -1 & 5 \end{bmatrix}$ verify that $BA = 6I$. Use the result to

solve the system : $x - y = 3, 2x + 3y + 4z = 17, y + 2z = 7$.

Q19. Use product $\begin{bmatrix} 1 & -1 & 2 \\ 0 & 2 & -3 \\ 3 & -2 & 4 \end{bmatrix} \begin{bmatrix} -2 & 0 & 1 \\ 9 & 2 & -3 \\ 6 & 1 & -2 \end{bmatrix}$ to solve the system of equations.

$$x - y + 2z = 1$$

$$2y - 3z = 1$$

$$3x - 2y + 4z = 2$$

Q20. Show that the matrix $A = \begin{bmatrix} 2 & 3 \\ 1 & 2 \end{bmatrix}$ satisfies the equation $A^2 - 4A + I = O$, where I is 2×2 identity matrix and O is 2×2 zero matrix. Using this equation, find A^{-1} .

Q21. Prove that the height of the cylinder of maximum volume that can be inscribed in a sphere of radius R is $2R/\sqrt{3}$. Also find the maximum volume.

Q22. Mohini purchased a rectangular parallelepiped shaped box and a spherical ball inside it as a showpiece. The sides of the box are $x, 2x$ and $x/3$, and the radius of the sphere is y .

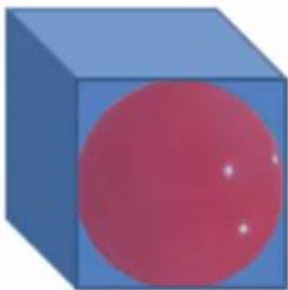

The sum of the surface area of the parallelepiped and sphere is given to be constant.

Based on the above information, answer the following questions:

- Let the constant surface area given to be S , then what is the relation between x and y ?
- If the combined volume is denoted by V , then what is the value of V ?
- If volume V is minimum, then how are x and y is related to each other?

Q23. If $\sin [\cot^{-1} (x + 1)] = \cos (\tan^{-1} x)$, then find x .

Prove that the Greatest Integer Function $f: \mathbb{R} \rightarrow \mathbb{R}$, given by $f(x) = [x]$ is neither one-one nor onto. Where $[x]$ denote the greatest integer less than or equal to x .

Q24. If $y = 500e^{7x} + 600e^{-7x}$, show that $\frac{d^2 y}{dx^2} = 49y$.

SUBJECT: PHE

1. Define the term "Sports Management" and explain its importance in the context of modern sports.

2. What are the key functions of sports management? Provide examples for each function.

- 3.Explain the league tournament format. How is it different from the knockout tournament? Give example through tabular method.
- 4.Describe the steps involved in organizing a sports event.
5. Describe the procedure for creating a fixture in a knockout tournament with 16 teams
6. Discuss the physical and psychological benefits of sports participation for children.
- 7.What are the common barriers faced by women in sports? Suggest ways to overcome these barriers.
8. How does participation in sports influence the social development of children?
- 9.Explain the concept of "gender equity in sports" and its significance.
- 10.What measures can be taken to encourage more girls and women to participate in sports?
- 11.Name and describe any three asanas that are beneficial for preventing obesity.
- 12.How can regular practice of yoga asanas help in managing diabetes? Mention any two specific asanas with their benefits and contraindications.
- 13.Identify and explain two asanas that can help in relieving asthma symptoms.
- 14.Discuss the role of asanas in controlling hypertension. Provide examples of effective asanas with the help of picture diagram and also write their contraindications.
- 15.Which asanas are recommended for alleviating back pain? Describe their benefits and the correct way to perform them.
- 16.What is the importance of physical education for children with special needs (CWSN)?
- 17.Explain the concept of "inclusive education" in the context of physical education.
- 18.Describe the role of physical activities in the overall development of CWSN.
- 19.What adaptations can be made in physical education programs to accommodate CWSN?
- 20.Discuss the benefits of sports and physical activities for children with autism.

SUBJECT: NCC

- I. **Make a file :**
 - a. Drill and Types of drill.
 - b. Characteristics of rifle .22
- II. Describe the various **gallantry** and **non-gallantry awards** awarded in Armed Forces during the time of peace and war.
 - Make a **hierarchy** of all the **military decorations** given during war and peace
 - Give a brief **description** of the awards and **paste pictures**
 - Make a **list of all awardees** of the highest military decoration- Param Vir Chakra (PVC)
 - Collect information about **Captain Vikram Batra** and mention his contribution in the history of armed forces.

Q1. Write a short note on parasailing.

Q2. Enlist the safety measures to be taken while parasailing that are mentioned by parasailing council.

Q3. Enumerate the pre-flight instructions that a parasailing operator gives to a parascender

Q4. Indo- Pak had witnessed the various wars. Write a short note on Indo-Pak War of 1971.

Q5. How Battle of Dograi came into existence?

Q6. Elaborate the various methods of judging distance in the battle field.

Q7. Enlist the various features of service protractor.

Q8. Bearings help to find the direction of an object. Explain the various types of bearings.

Q9. Enumerate the various characteristics of INSAS 5.56 mm.

Q10. Parasailing is an adventure activity. Explain the various types of parasailing.

Q11. History always gives us the blue print for future. What is significance of military history?

Q12. Water is the basic necessity of life. What are the various methods that can be used for purifying the water?

Q13. Hygiene is the key for good health. Explain the various components of personal hygiene with context to the given statement.

Q14. Write a short note on:

- a. Snap
- b. Loudness

Q15. One should be well-versed while tackling a weapon. What are the essentials of a good shooting?

Q16. Our constitution consists of various do's and don'ts. Enumerate the various directive principles in detail.

Q17. Write a short note on IMA Dehradun.

Q18. What are the various conditions when distance is overestimated?

Q19. NCC is based on discipline. Drill is an important activity to shift number of people in a disciplined manner. What are the importance of drill in the life of a NCC cadet?

Q20. Abusing is a punishable act. What is child abuse and explain the various forms of child abuse?

NOTE: DO THE WORKSHEET ON PRACTICAL/A4 SIZED SHEETS AND KEPT PROPERLY IN A FILE FOR SUBMISSION. MAKE A SEPARATE FILE FOR QUESTION NO I and II.

